

Eclipse RatioMatic Burners

Model RM200

Version 3

Main Specifications - RM200

PARAMETER		SPECIFICATIONS				
		English		Metric		
Maximum input	Note: Contact factory for varying chamber pressures or pressures outside the range: -5.0 to 2.0" w.c. (-12,4 to 5,0 mbar)	Motor frequency	Capacity @ Chamber Pressure			
			BTU/hr @ "w.c.	kW @ mbar		
		60 Hz packaged blower	2,450,000	-5.0	718	-12,4
			2,350,000	-3.0	689	-7,5
		50 Hz packaged blower*	2,150,000	0.0	630	0,0
			2,050,000	1.0	601	2,5
1,950,000	2.0	571	5,0			
Minimum input		BTU/hr		kW		
		40,000		12		
Main gas inlet pressure • fuel pressure at ratio regulator inlet	Natural gas Propane or Butane	15 to 55 "w.c. 15 to 30 "w.c.		38 to 137 mbar 38 to 75 mbar		
High fire flame length • measured from the outlet end of the combustor	Natural gas Propane or Butane	50 in 60 in		1300 mm 1500 mm		
Maximum chamber temperature	Alloy tube SiC tube	°F		°C		
		1500 1900		815 1038		
Flame detection	Flame rod or UV scanner					
Fuel	Natural Gas, Propane or Butane. For any other mixed gas, contact Eclipse Combustion for orifice sizing					

* At negative chamber pressures, capacities must be reduced. Contact factory.

- All information is based on laboratory testing. Different chamber size and conditions will affect the data.
- Maximum inputs are given for the standard combustion air blower without an air filter.
- All inputs based upon gross calorific values and standard conditions; 1 atmosphere, 70° F (21°C).
- Eclipse reserves the right to change the construction and/or configuration of our products at any time without being obliged to adjust earlier supplies accordingly.

Performance Graphs
RatioMatic RM200

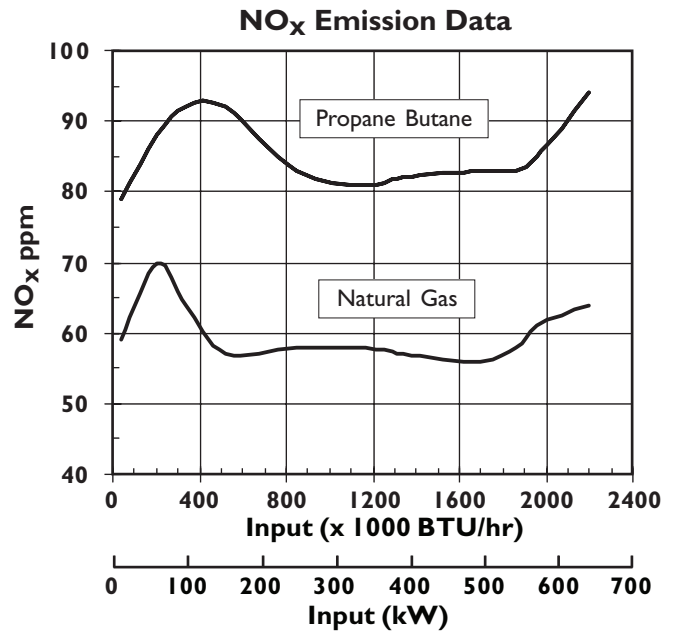
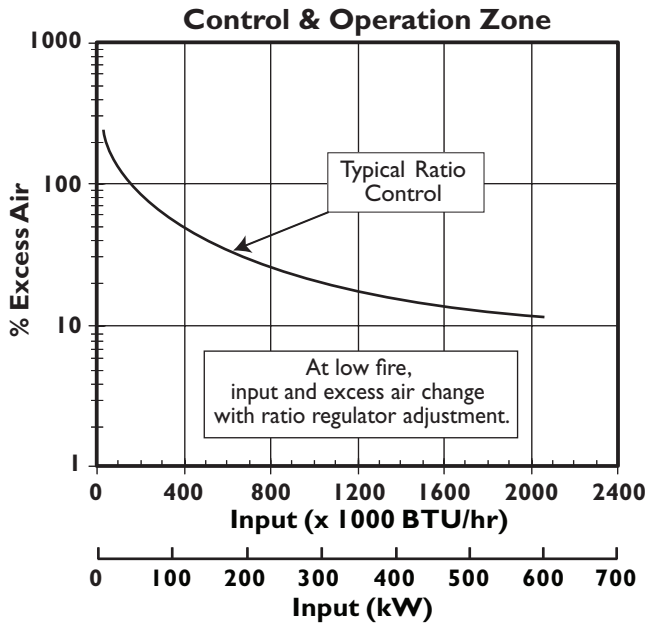

Notes on emission data	
<p>NO_x emission data is given for:</p> <ul style="list-style-type: none"> • Ambient combustion air ~70° F (20° C) • Less than 700°F (370°C) firing chamber • Minimal process air velocity • Low fire input adjusted to 40,000 BTU/hr (12kW) • ppm volume dry at 3% O₂ • Neutral chamber pressure 	<p>Emissions are influenced by:</p> <ul style="list-style-type: none"> • Chamber conditions • Fuel type • Firing rate • Ratio regulator adjustment • Combustion air temperature
<p align="center">CO emission is largely influenced by chamber conditions. Contact your local Eclipse representative for an estimate of CO emission on your application.</p>	

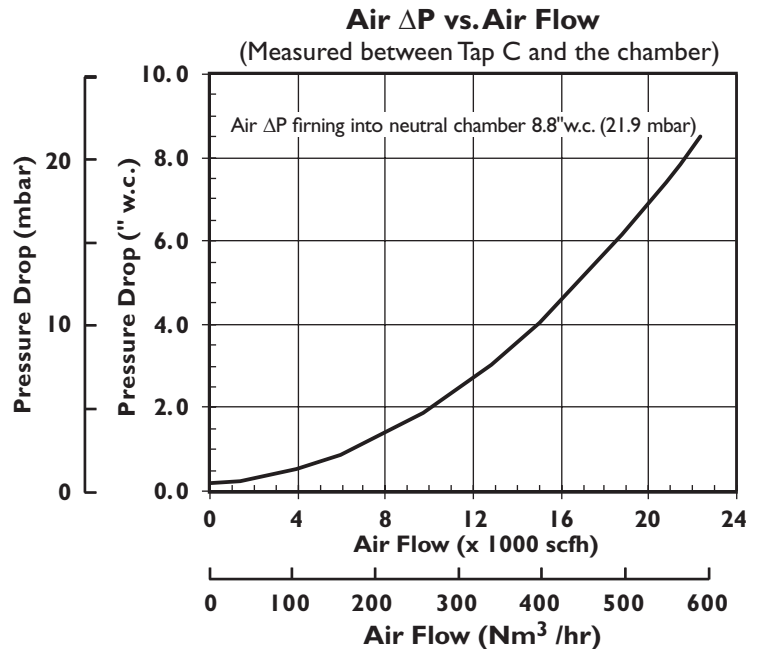
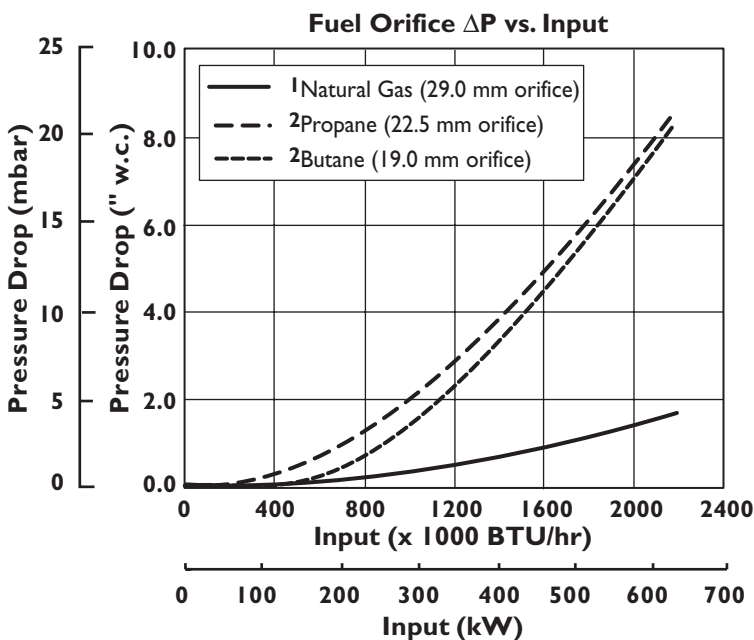

¹Natural Gas ΔP measured between Taps B and D
²Propane and Butane ΔP measured between Tap B and the chamber

Dimensions-RM200

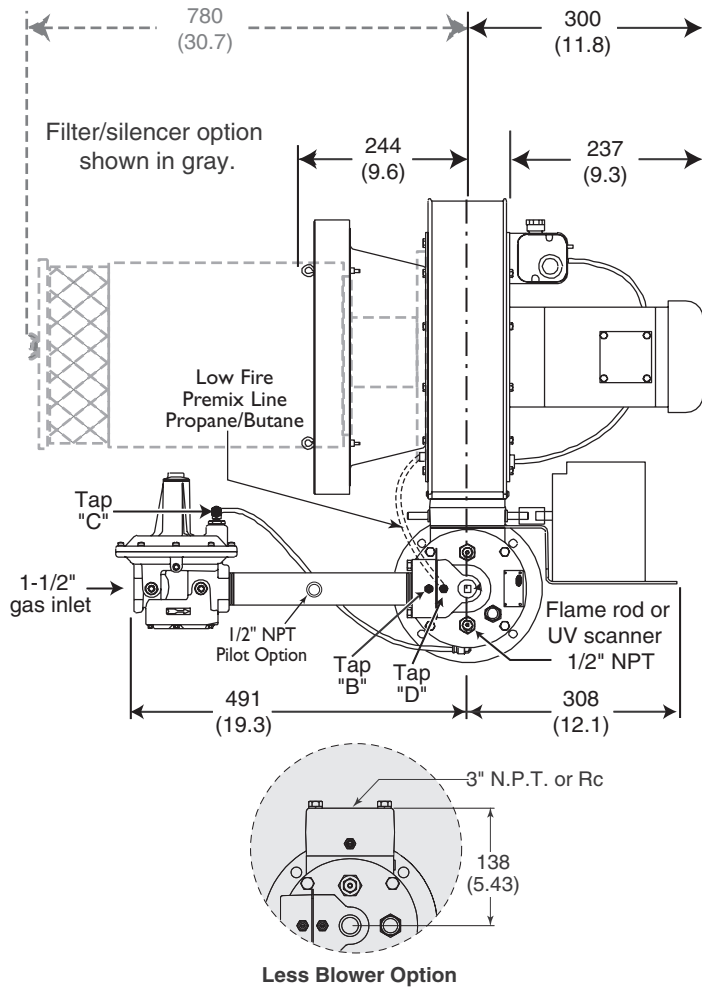

Dimensions in mm (in)

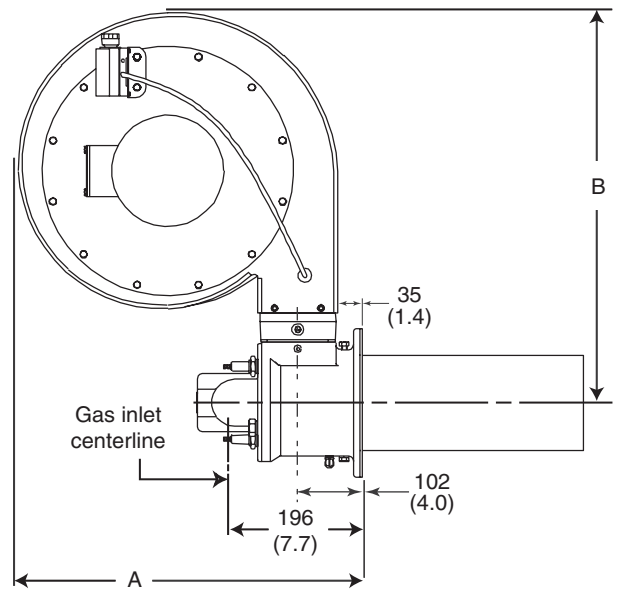

	A	B
50 Hz	575 (22.6)	650 (25.6)
60 Hz	502 (19.8)	576 (22.7)

Approximate weight: 105 lb (48 kg)

Combustor types

Alloy tube

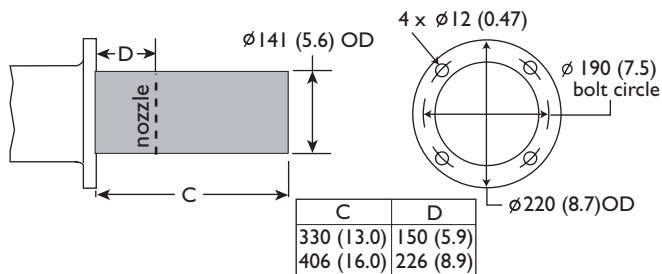

SiC tube

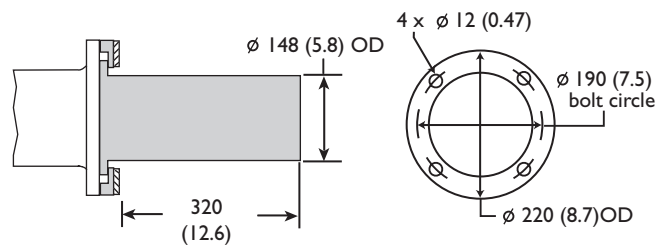

Burner configuration

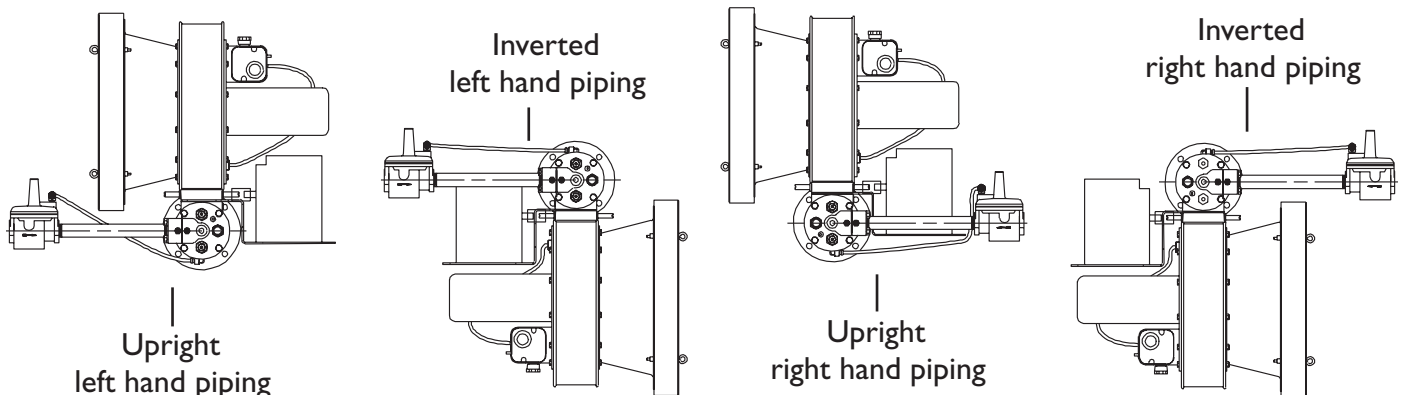



Offered By:

Power Equipment Company
2011 Williamsburg Road
Richmond, Virginia 23231
Phone (804) 236-3800
Fax (804) 236-3882

www.peconet.com